



Electrolux
PROFESSIONAL

**Modular Cooking Range Line
thermaline 90 - Half Module
Freestanding Electric Fry Top, 1 Side,
H=800**

ITEM # _____

MODEL # _____

NAME # _____

SIS # _____

AIA # _____



589552 (MCHAFADDAO)

Electric Fry Top with smooth chrome Plate, one-side operated

589560 (MCHCFADDAO)

Electric Fry Top with ribbed chrome Plate, one-side operated

Short Form Specification

Item No. _____

Unit constructed according to DIN 18860_2 with 20 mm drop nose top and 70 mm recessed plinth. Internal frame for heavy duty sturdiness in stainless steel. 2 mm top in 1.4301 (AISI 304). Flat surface construction, easily cleanable. THERMODUL connection system enables seamless worktop when units are connected and avoids soil penetrating. Chromium-plated mild steel cooking surface with non-stick finishing for optimal grilling. Powerblock heating system for optimal temperature distribution. Large drain hole allows draining of cooking juices into a large collector. Overheat protection switches off the supply in case of overheating. Standby function saves energy and quickly recovers maximum power. Metal knobs with embedded hygienic silicon "soft" grip enable easier handling and cleaning. IPX5 water resistant certification. Configuration: Freestanding, One-side operated.

Main Features

- Large drain hole on cooking surface permits the draining of residual cooking juices into a large collector placed under the cooking surface.
- Overheat protection: the temperature sensor switches off the supply in case of overheating.
- Stainless steel high splash guards on the rear and sides of cooking surface.
- Units have separate controls for each half module of the cooking surface.
- All major components may be easily accessed from the front.
- THERMODUL connection system creates a seamless work top when units are connected to each other thus avoiding soil penetrating vital components and facilitating the removal of units in case of replacement or service.
- Metal knobs with embedded hygienic "soft-touch" grip for easier handling and cleaning. The special design of the controls prevents infiltration of liquids or soil into vital components.
- Large visible digital display manufactured in tempered glass to resist heat and chemicals, showing temperatures or power settings. The display also shows on/off status of the appliance and on/off status of the heating elements.
- Powerblock heating system for optimal temperature distribution.

Construction

- 2 mm top in 1.4301 (AISI 304).
- Unit constructed according to DIN 18860_2 with 20 mm drop nose top and 70 mm recessed plinth.
- Flat surface construction with minimal hidden areas to easily clean all surfaces
- Cooking surface in chromium-plated mild steel with non-stick finishing for optimum grilling results.
- IPX5 water resistance certification.
- Internal frame for heavy duty sturdiness in stainless steel.
- Cooking surface to be completely smooth or completely ribbed.

Sustainability



- Standby function for energy saving and fast recovery of maximum power.

APPROVAL: _____



Experience the Excellence
www.electroluxprofessional.com



Optional Accessories

- Connecting rail kit, 900mm PNC 912502
- Stainless steel side panel, 900x800mm, freestanding PNC 912511
- Stainless steel front kicking strip, 400mm width PNC 912594
- Stainless steel side kicking strips left and right, freestanding, 900mm width PNC 912621
- Stainless steel side kicking strips left and right, back-to-back, 1810mm width PNC 912627
- Stainless steel plinth, freestanding, 400mm width PNC 912916
- Connecting rail kit: modular 90 (on the left) to ProThermetic tilting (on the right), ProThermetic stationary (on the left) to ProThermetic tilting (on the right) PNC 912975
- Connecting rail kit: modular 80 (on the right) to ProThermetic tilting (on the left), ProThermetic stationary (on the right) to ProThermetic tilting (on the left) PNC 912976
- Endrail kit, flush-fitting, left PNC 913111
- Endrail kit, flush-fitting, right PNC 913112
- Scraper for smooth plates (only for 589552) PNC 913119
- Scraper for ribbed plates (only for 589560) PNC 913120
- Endrail kit (12.5mm) for thermaline 90 units, left PNC 913202
- Endrail kit (12.5mm) for thermaline 90 units, right PNC 913203
- Stainless steel side panel, left, H=800, flush PNC 913224
- Stainless steel side panel, left, H=800, flush PNC 913225
- T-connection rail for back-to-back installations without backsplash (to be ordered as S-code) PNC 913227
- Insert profile d=900 PNC 913232
- Perforated shelf for warming cabinets and cupboard bases (one-side operated TL80-85-90 and two-side operated for TL80) PNC 913233
- Energy optimizer kit 14A - factory fitted PNC 913244
- Endrail kit, (12.5mm), for back-to-back installation, left PNC 913251
- Endrail kit, (12.5mm), for back-to-back installation, right PNC 913252
- Endrail kit, flush-fitting, for back-to-back installation, left PNC 913255
- Endrail kit, flush-fitting, for back-to-back installation, right PNC 913256
- Side reinforced panel only in combination with side shelf, for freestanding units PNC 913259
- Side reinforced panel only in combination with side shelf, for back-to-back installations, left PNC 913277
- Side reinforced panel only in combination with side shelf, for back-to-back installation, right PNC 913278
- Shelf fixation for TL80-85-90 one-side operated, TL80 two-side operated PNC 913279
- Filter W=400mm PNC 913663
- Stainless steel dividing panel, 900x800mm, (it should only be used between Electrolux Professional thermaline Modular 90 and thermaline C90) PNC 913673
- Electric mainswitch 25A 4mm² NM for modular H800 electric units (factory fitted) PNC 913676
- Stainless steel side panel, 900x800mm, flush-fitting (it should only be used against the wall, against a niche and in between Electrolux Professional thermaline and ProThermetic appliances and external appliances - provided that these have at least the same dimensions) PNC 913689

Recommended Detergents

- C41 HI-TEMP RAPID DEGREASER, 1 pack of six 1 lt. bottles (trigger incl.) PNC 0S2292



Electric

Supply voltage: 400 V/3N ph/50/60 Hz
Total Watts: 5.1 kW

Key Information:

Cooking Surface Depth: 615 mm
Cooking Surface Width: 300 mm
Working Temperature MIN: 80 °C
Working Temperature MAX: 280 °C
External dimensions, Width: 400 mm
External dimensions, Depth: 900 mm
External dimensions, Height: 800 mm
Storage Cavity Dimensions (width): 340 mm
Storage Cavity Dimensions (height): 330 mm
Storage Cavity Dimensions (depth): 740 mm
Net weight: 91 kg
Configuration: On Base;One-Side Operated
Cooking surface type:
589552 (MCHAFADDAO) Smooth
589560 (MCHCFADDAO) Ribbed
Cooking surface - material: Chromium Plated mild steel mirror

Sustainability

Current consumption: 7.4 Amps

Front

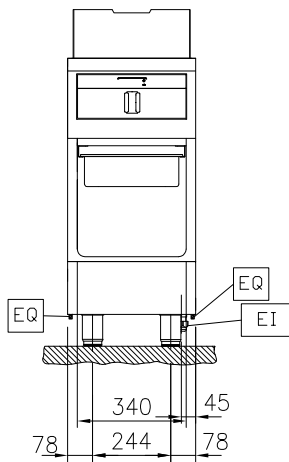

Front

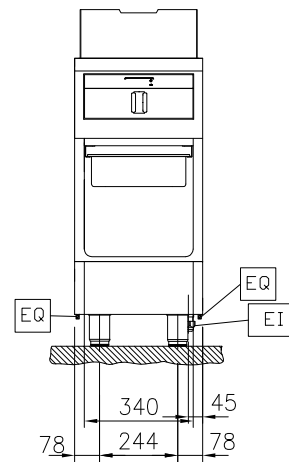

Side

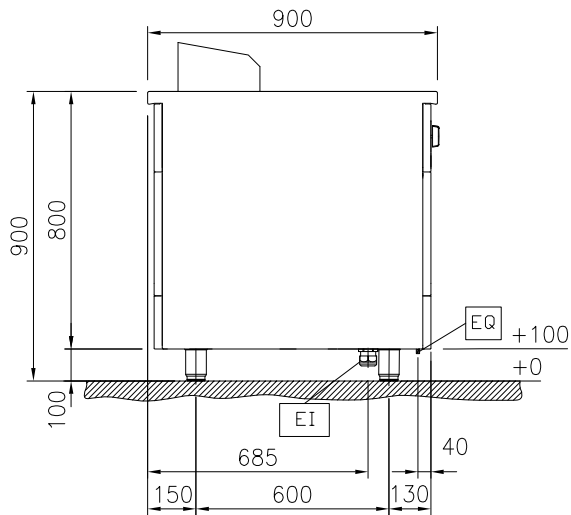

Side

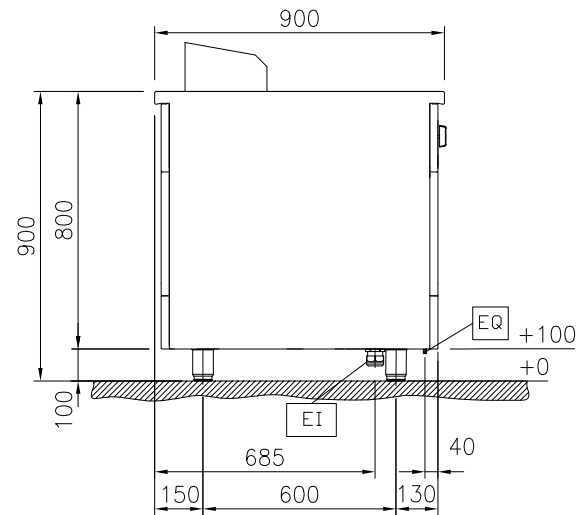

EI = Electrical inlet (power)
 EQ = Equipotential screw

EI = Electrical inlet (power)
 EQ = Equipotential screw

Top

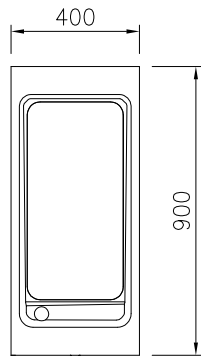

Top

